



**alchemia
nova**

*institute for innovative
phytochemistry
@ closed loop processes*

stand-up innovation

Materials in a circular economy

Vienna 12th of June 2019

Johannes Kissler



www.alchemia-nova.net

ALL GROWTH INVOLVES CHOOSING LOVE OVER FEAR

- Bryant Mac Gill



Simple Reminders
SIMPLEREMINDERS.COM



Proliferation of seals and certification schemes



**alchemia
nova**

*institute for innovative
phytochemistry
@ closed loop processes*



Selected certification labels for food products



**alchemia
nova**

*institute for innovative
phytochemistry
@ closed loop processes*



CodeCheck

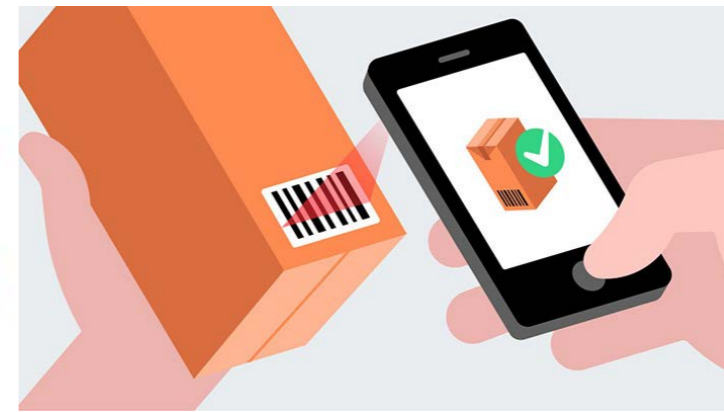

**alchemia
nova**

*institute for innovative
phytochemistry
@ closed loop processes*

Finde bessere und nachhaltigere
Lebensmittel für dich und deine Familie.

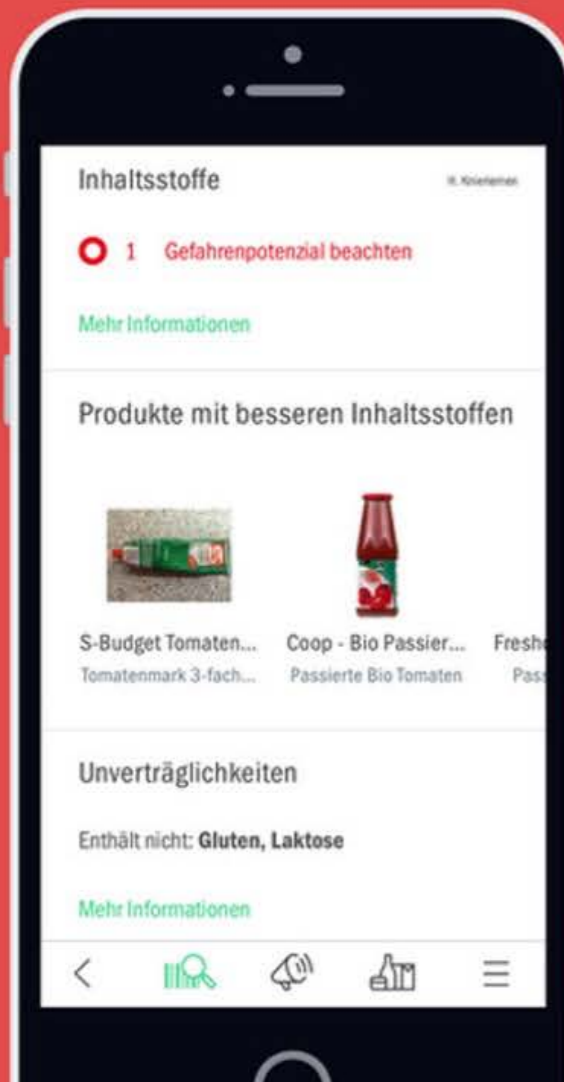

Du möchtest Kosmetik ohne
Hormone & Chemie? Scanne Produkte
direkt beim Einkauf.

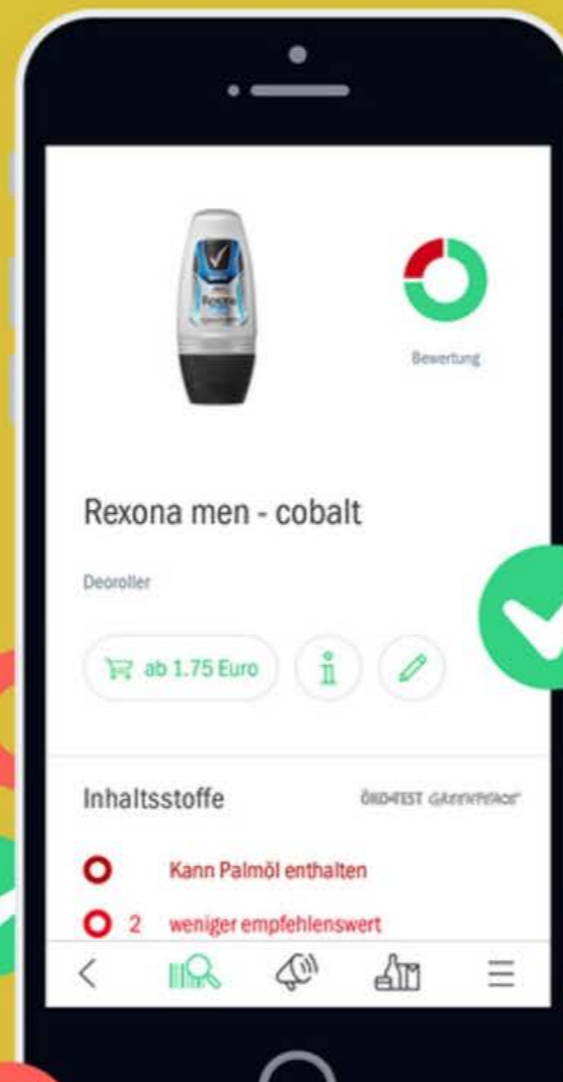

Die besten unabhängigen Experten
bewerten deine alltäglichen Produkte.

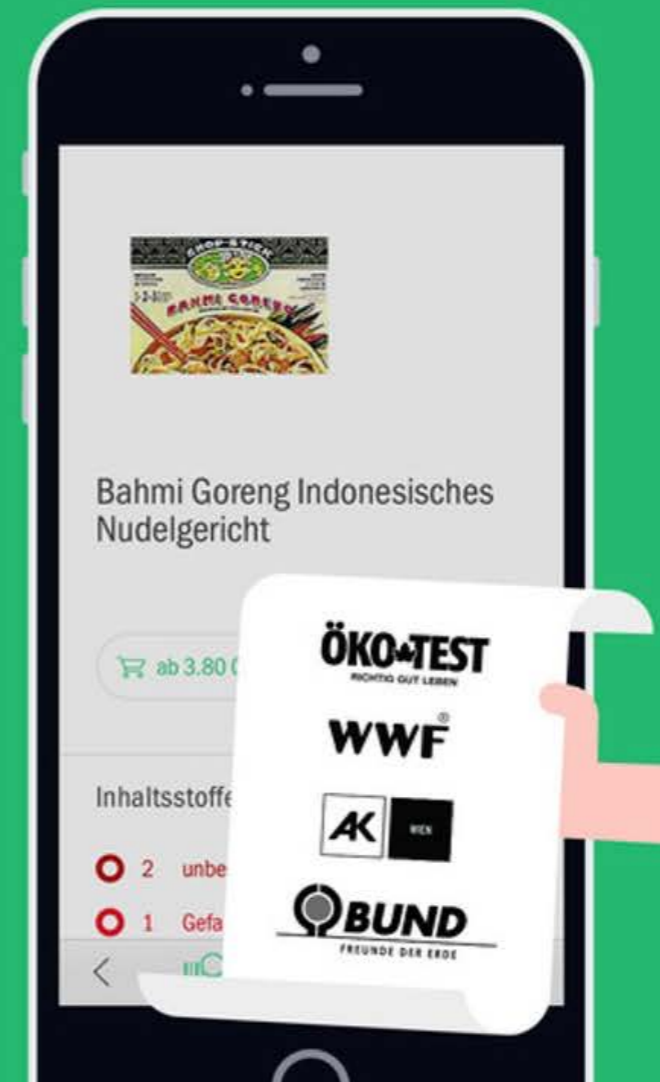



**alchemia
nova**

*institute for innovative
phytochemistry
@ closed loop processes*

SCHWERMETALLE IN KINDERSPIELZEUG

①

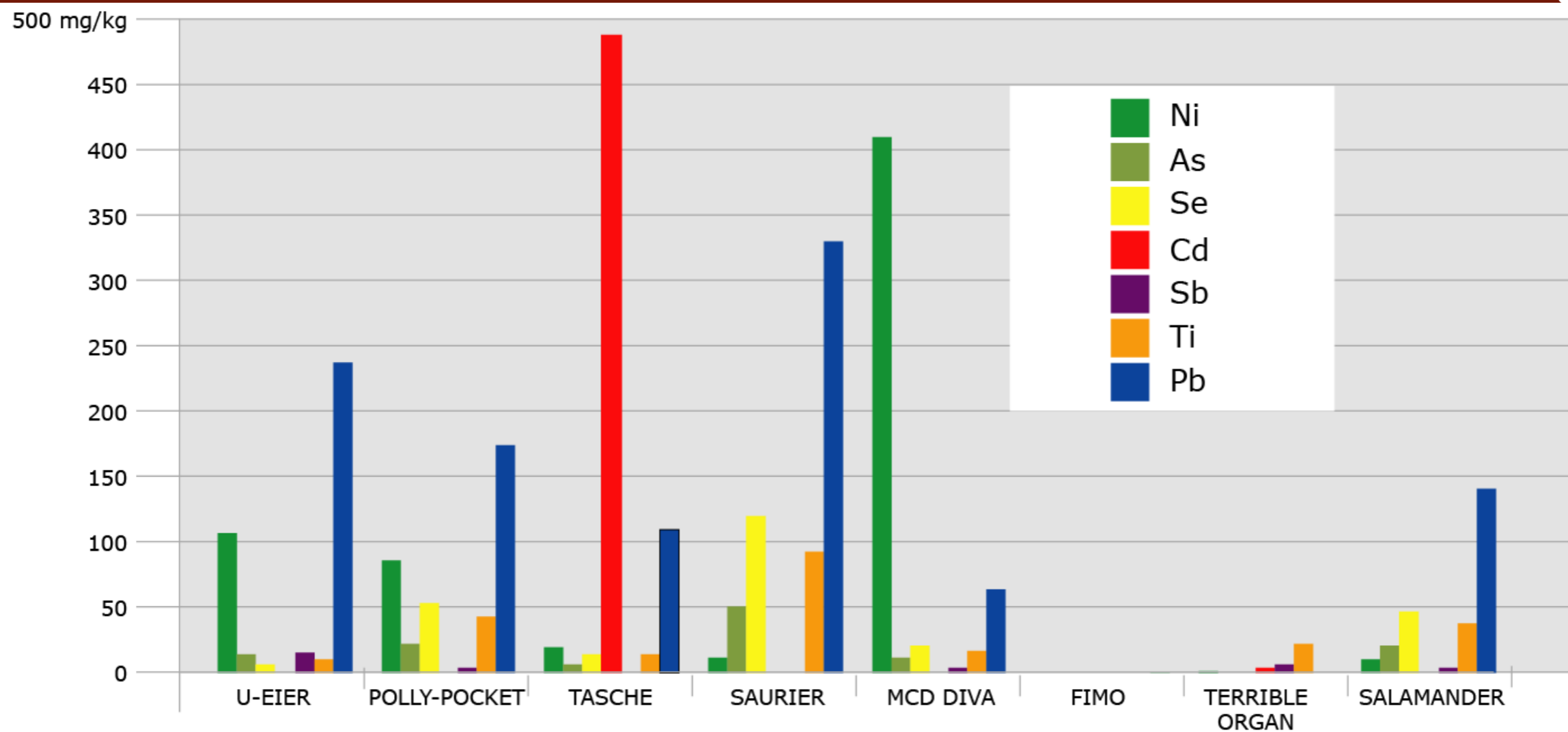



**alchemia
nova**

institute for innovative
phytochemistry
⊕ closed loop processes

Cradle to Grave

The last industrial revolution

- Pollutants in air, water, soil**
- Mountains of waste**
- Regulations = Protection against too quick intoxication**
- Productivity = as few workers as possible**
- Progress = Exploitation of resources**
- Loss of biodiversity**

Are we stupid...?



Natural and technical cycle → Disruptive innovations



**alchemia
nova**
institute for innovative
phytochemistry
@ closed loop processes

Nature's example



Circular design

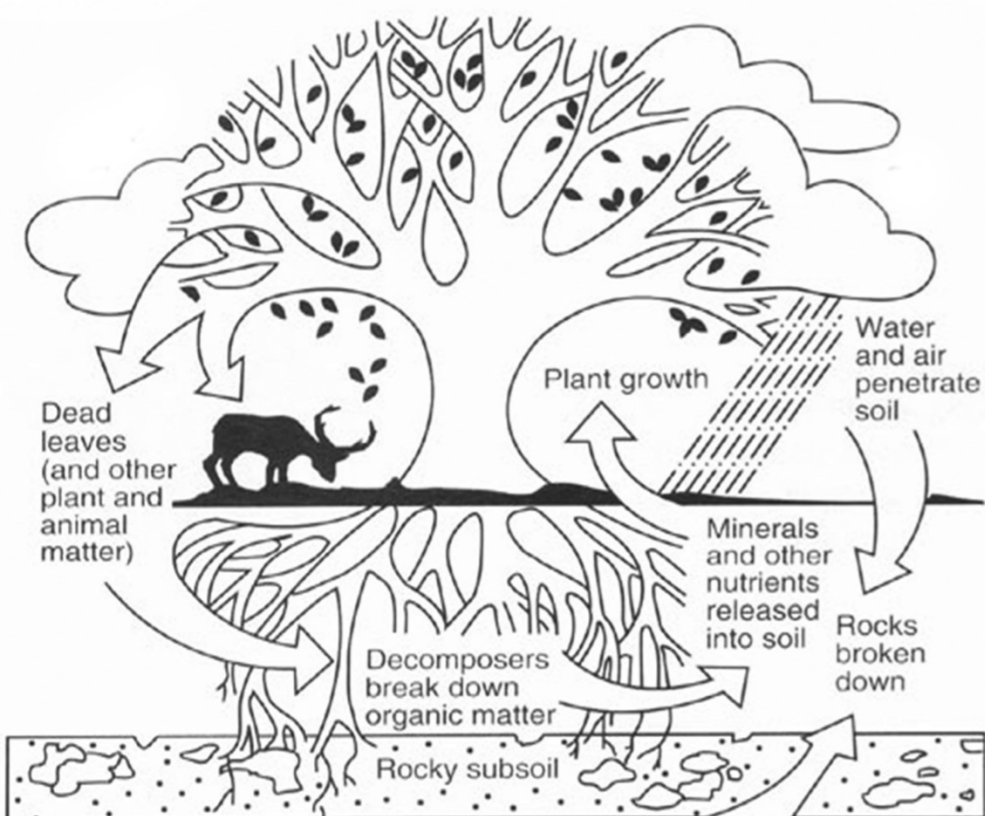

ecosystem
services

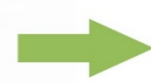

nutrient
cycle

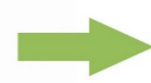

education

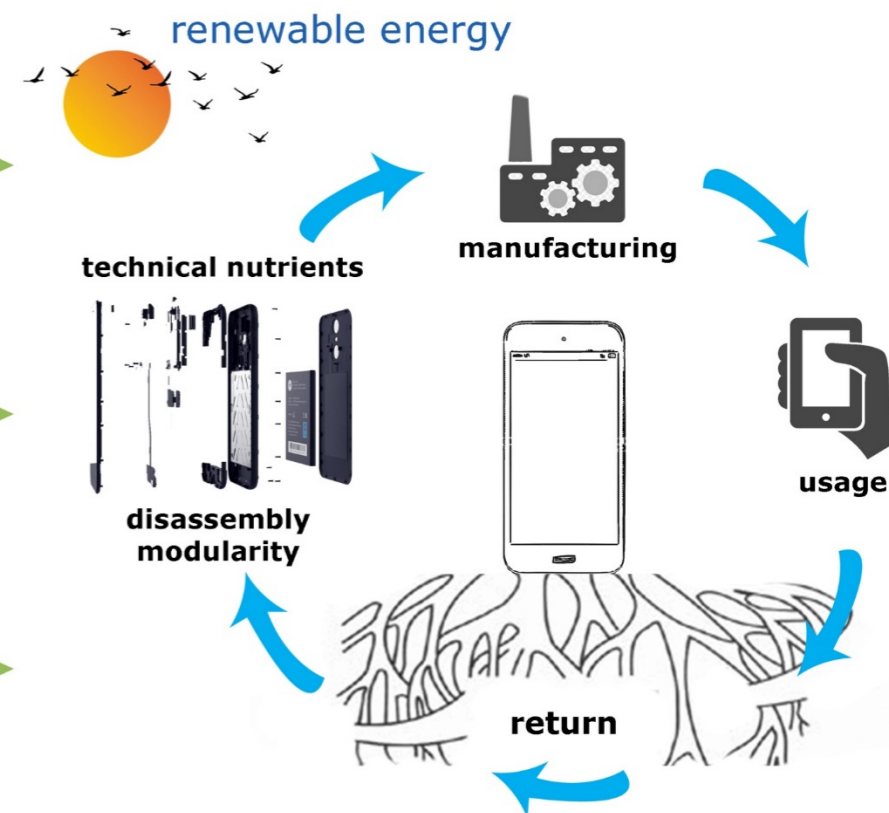



**alchemia
nova**
institute for innovative
phytochemistry
⊕ closed loop processes

Cradle to Cradle®



Take → **Make** → **Regenerate**





**alchemia
nova**

*institute for innovative
phytochemistry
⊕ closed loop processes*

CRADLE TO CRADLE : THE AIM IS EFFECTIVITY – A NEW QUALITY

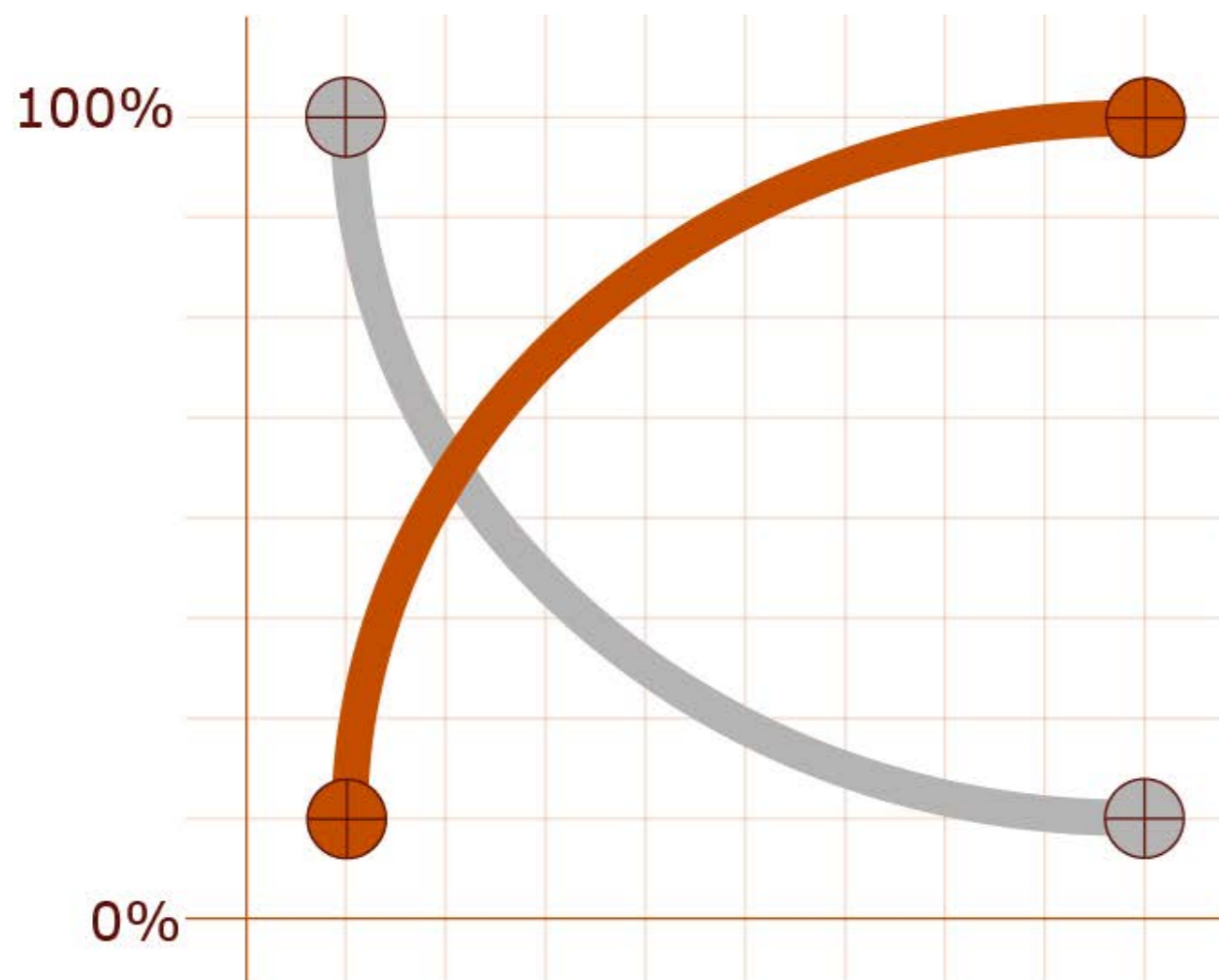

ECOEFFECTIVITY

OPTIMISE
"POSITIVE LISTS"

REDUCE
"NEGATIVE LISTS"

ECOEFFICIENCY





**alchemia
nova**

*institute for innovative
phytochemistry
⊕ closed loop processes*

ABC-X CHARACTERISATION

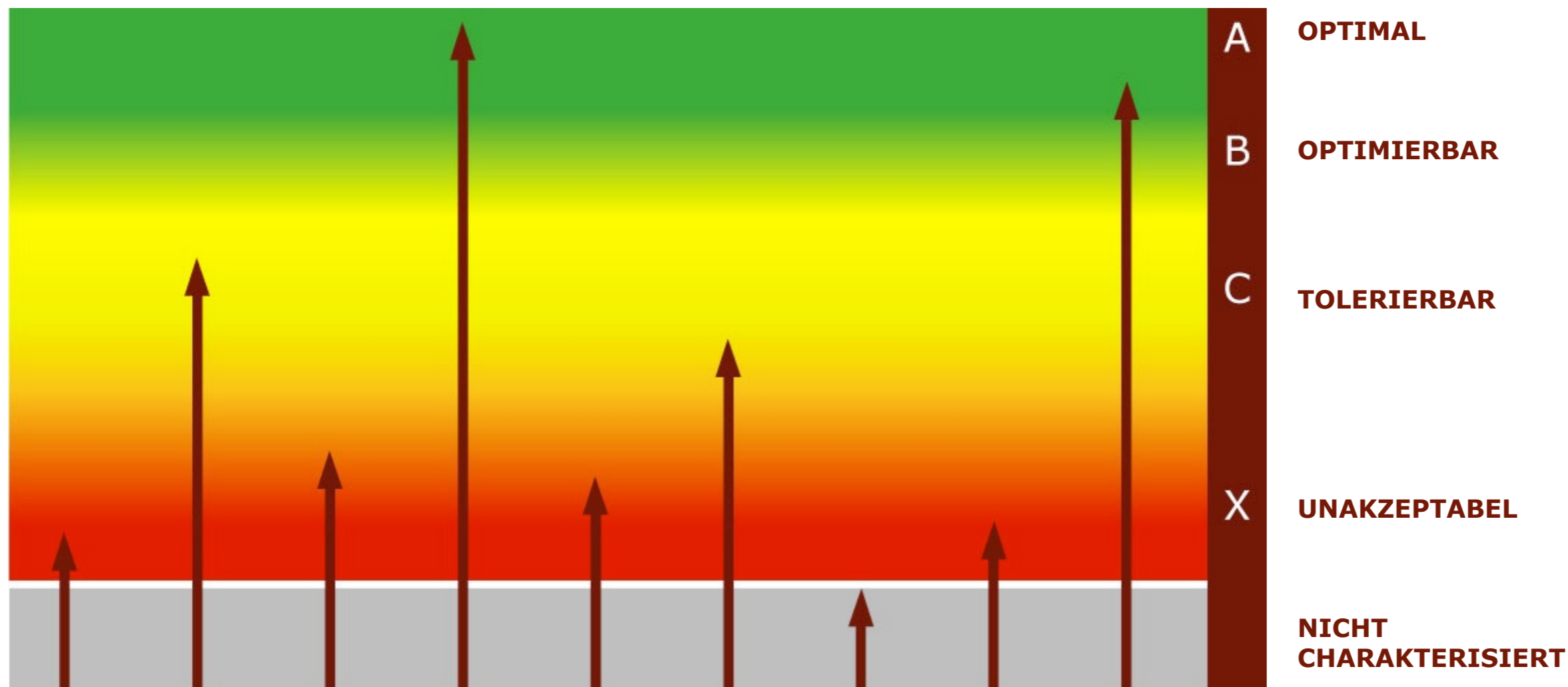

SYSTEMATIC CATEGORISATION AND SUBSTITUTION OF COMPONENTS



EXAMPLE FOR THE ANALYSIS OF MATERIALS



alchemia
nova

#	Chemical Name		Raw material	Human Toxicity	Eco Toxicity	Biodegradation
1	SODIUM LAURETH SULFATE	9.600				
2	COCAMIDOPROPYL BETAINE	6.043				
3	PROPAN/BUTAN (Aerosolmischung)	5.330				
4	GLYCERIN	4.820				
5	PARAFFIN OIL Low Viscosity	3.490				
6	ALCOHOL	2.202				
7	PARAFFIN OIL Medium Viscosity (Type 1)	1.960				
8	DISODIUM COCOYL GLUTAMATE	1.789				
9	PARAFFIN OIL Medium Viscosity (Type 2)	1.704				
10	ALUMINUM CHLOROHYDRATE(50%)	1.680				
11	LANOLIN	1.209				
12	PEG-3 DISTEARATE + SODIUM LAURETH SULFATE	1.190				
13	SODIUM COCOAMPHOACETATE	1.158				
14	STEARIC ACID	1.071				
15	CYCLOMETHICONE (Mixture D5/D6)	1.059				
16	C-16-ISOPARAFFIN	993				
17	CYCLOMETHICONE (D5)	961				
18	SOYBEAN OIL	945				
19	CAPRYLIC/CAPRIC TRIGLYCERIDE	916				
20	OCTYLDODECANOL	903				
21	CERA MICROCRISTALLINA + PARAFFINUM LIQUIDUM	899				
22	DISODIUM PEG-5 LAURYL CITRATE SULFOSUCCINATE + SODIUM LAURETH SULFATE	887				
23	MIPA LAURETH SULFATE + LAURETH-4 + COCAMIDE DEA	881				
24	ISOPROPYL PALMITATE	760				
25	POTASSIUM HYDROXIDE SOLUTION	705				



Positive vs. negative lists



**alchemia
nova**

*institute for innovative
phytochemistry
⊕ closed loop processes*

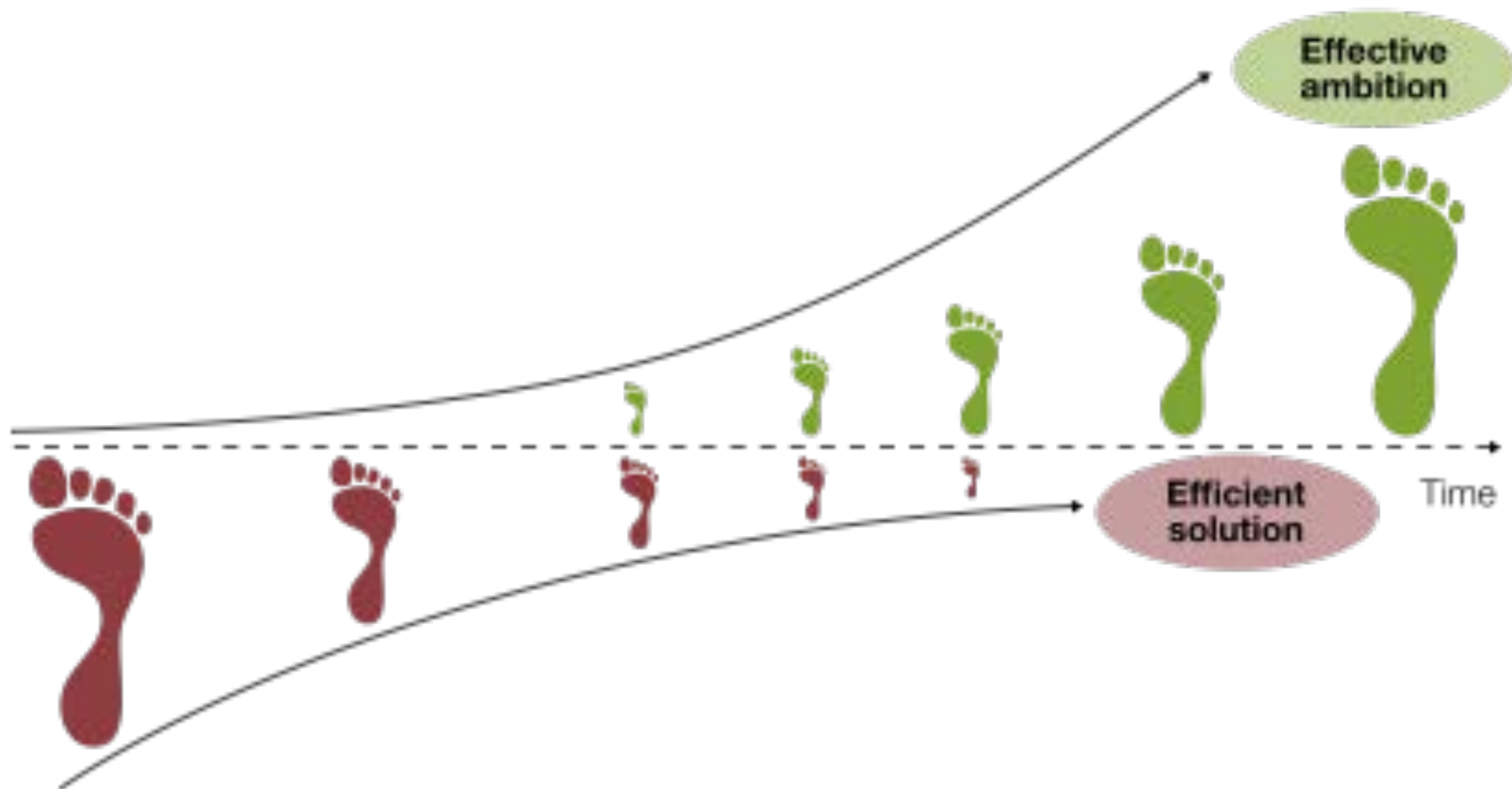

Zero Waste Hierarchy

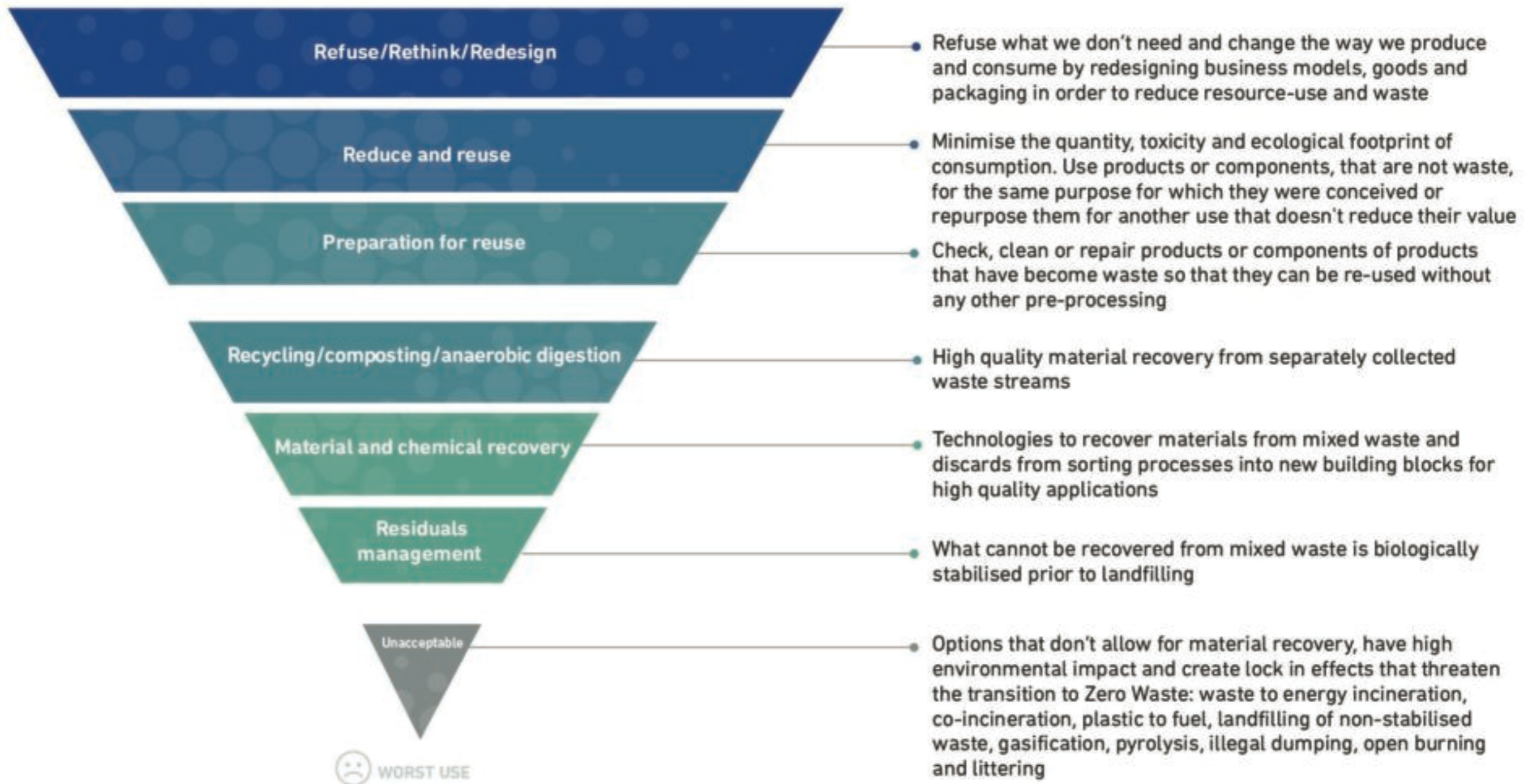

Life-circle-design



**alchemia
nova**

*institute for innovative
phytochemistry
⊕ closed loop processes*



RSA Innovate UK
www.greatrecovery.org.uk

www.circulardesignguide.com

www.circular-design.eu



Circular design example

Ecovative Mycelium Foundry



**alchemia
nova**

*institute for innovative
phytochemistry
@ closed loop processes*



Circular design example

Patagonia Worn Wear



**alchemia
nova**
institute for innovative
phytochemistry
@ closed loop processes

Repair Your Patagonia® Gear



Outerwear



Bottoms



Tops



Luggage



Fasteners

WORN



WEAR



IFIXIT



Material banks & modularity



**alchemia
nova**

*institute for innovative
phytochemistry
@ closed loop processes*



Flexline, Hegelo, NL



Spinnanker, AT

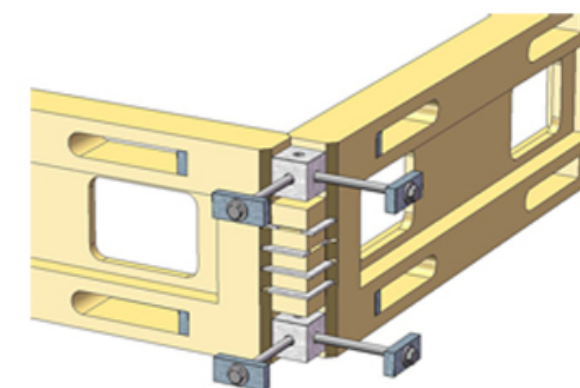
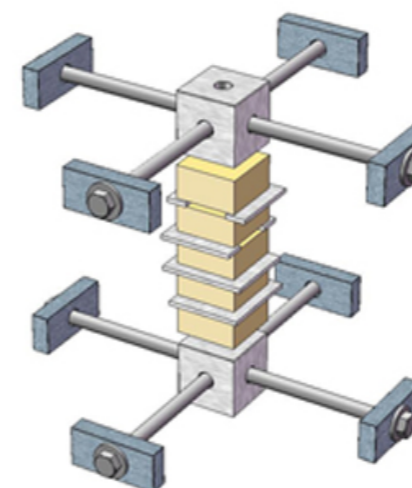

Holzbausystem Cross House, CH

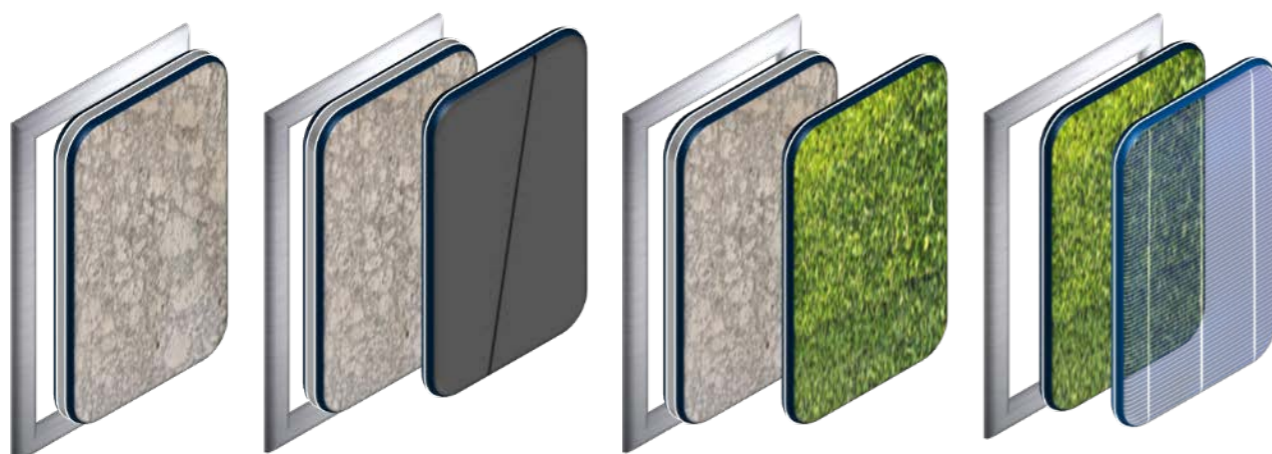

pvadapt.com



www.alchemia-nova.net

Material passport



**alchemia
nova**
institute for innovative
phytochemistry
@ closed loop processes

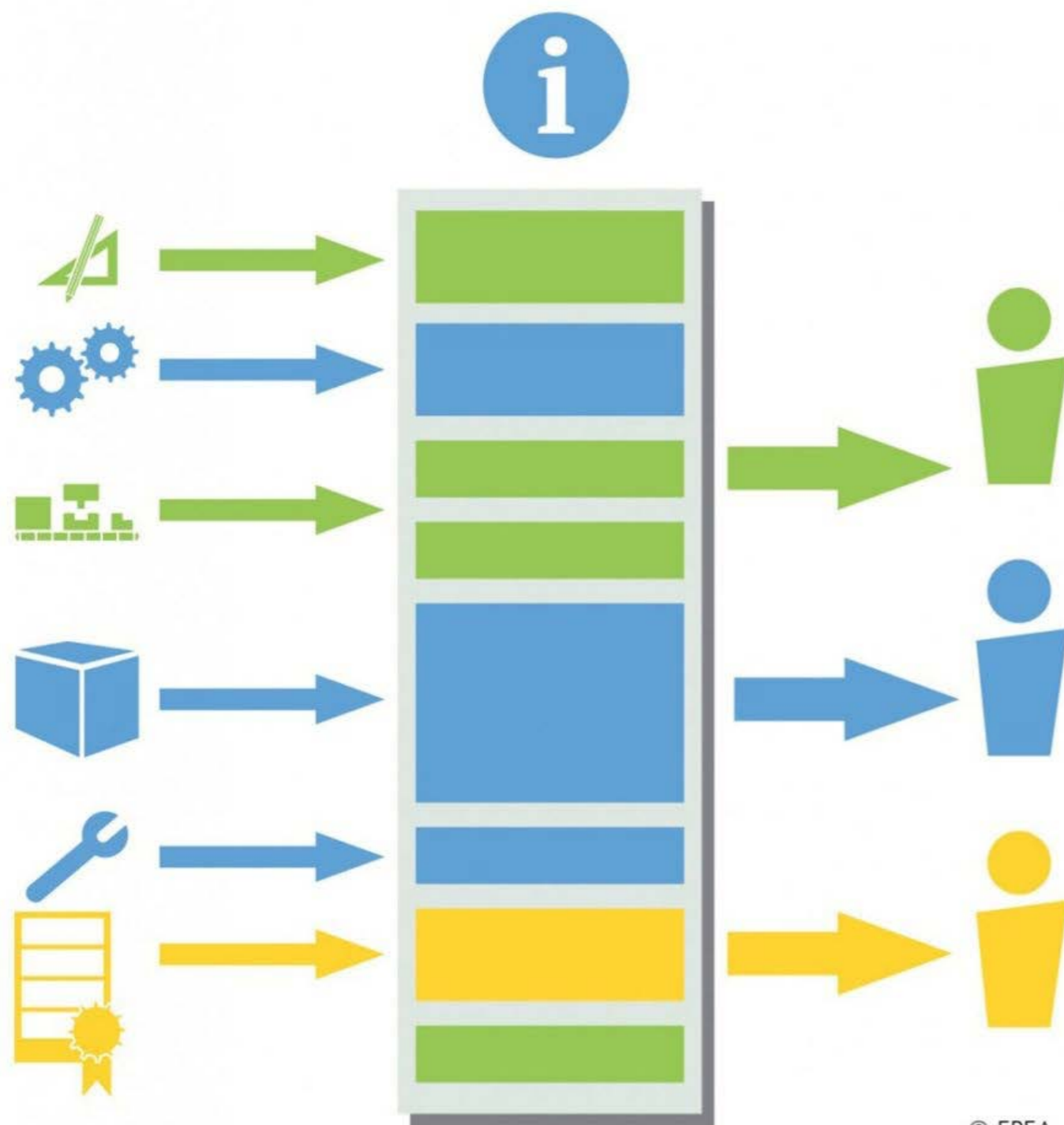

© EPEA

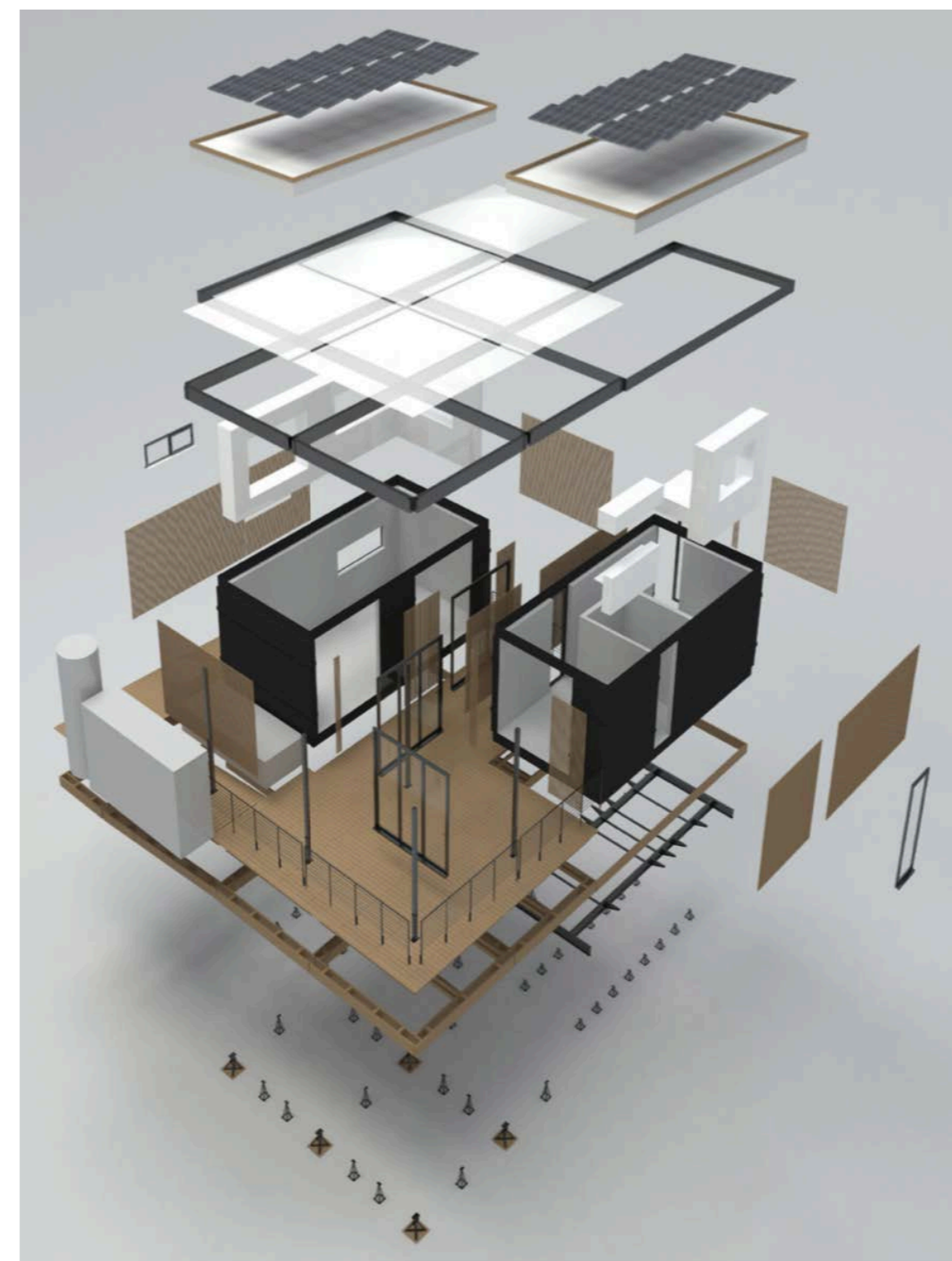

Thank you for your attention!
We are looking forward to further spreading
circular economy solutions!



**alchemia
nova**

*institute for innovative
phytochemistry @
closed loop processes*



**alchemia
nova**
greece



**alchemia
nova**
research

